

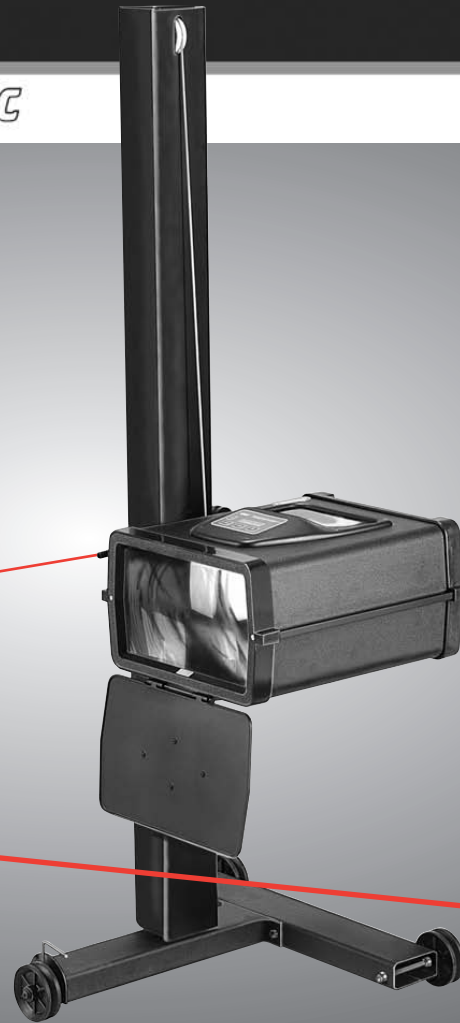

Wall Industries, LLC



Hoppy®

~~VISION 100~~

OPTICAL HEADLAMP AIMER INSTRUCTION MANUAL



Hoppy® Vision 100 Optical Headlamp Aimer

Congratulations! You now have the most affordable and easiest to use photometric headlamp aiming device in the world. The Vision 100 Optical Headlamp Aimer provides factory-precise aim analysis to the automotive aftermarket. Precision laser positioning, high technology photometric analysis, and computer-quick calculations make the Vision 100 one of the most accurate headlamp aiming devices available.

The versatility of the Vision 100 enables you to aim nearly any headlamp on any make of vehicle sold in North America. Standard, auxiliary, fog, rectangular, round, or aerodynamic headlamps can be precisely aimed, regardless of size.

The precise accuracy of laser technology is used to determine the vehicle centerline. Computer image processing technology forms the basis for the Vision 100. It analyzes the light pattern as it would appear on the roadway ahead of the vehicle. Upon positioning the Vision 100 in front of the headlamp, the headlamp low beam is analyzed and with simple directional arrows the user is directed to adjust the headlamp until a graphic X on a digital display shows that perfect aim has been achieved. Aiming pads or adapters are no longer a necessity. And the Vision 100 will not become obsolete when new headlamp designs are introduced.

Instruction Manual

	Page(s)
Table of Contents	2
Introduction / Contents -----	2
Hoppy Vision 100 Optical Aimer Contents	
Vision 100 Preparation -----	3
Aimer Assembly	
Battery Pack	
Aimer Test	
Vision 100 Component Description -----	4
Vision 100 Parts Identification	
Set Floor Slope -----	5
Vehicle Set Up and Aimer Alignment -----	6
Vehicle Set Up and Aimer Alignment -----	7
Aimer Alignment to Lamp -----	8
Position Aimer	
Find Optical Center of Lamp	
Lamp Audit / Lamp Aim -----	9
Vertical Beam Aim Guidelines	
Audit Lamp	
Aim Lamp / Aim Other Lamps	
Aim Guidelines / Internal Screens -----	10
Vision 100 Calibration -----	11
Equipment Calibration	
Specifications -----	12
Trouble Shooting -----	13, 14, 15, 16 & 17
Frequently Asked Questions -----	18
Notes -----	19
Warranty -----	(Back Cover)

This user manual should be read in its entirety before operating the Vision 100. If you have any questions, please contact a Wall Industries, LLC representative, at **1-877-343-7703 for information and assistance.**



Aimer Assembly

Assembly instructions are provided on a separate sheet included with this Vision 100 Headlamp Aimer.

Questions? Call **1-877-343-7703** for **information and assistance.**

Battery Pack

After the assembly of your aimer is complete, you should **charge the battery pack overnight.** To gain maximum capacity the battery pack should go through several charge / discharge cycles. Your aimer is designed to operate continually for over 3 hours. This will equate to approximately 25-30 headlamp aims. When the battery pack is close to discharge the display will indicate a "Battery Low" condition. At this time you have approximately 30 minutes of operation remaining. The unit will continue to display the "Battery Low" condition approximately every 3-4 minutes until the battery is sufficiently discharged. At that point the unit will automatically shut off to protect the Ni-Cad battery pack. You can, however, **plug the wall charger to the unit and continue to operate.** You then should charge the unit overnight to restore full battery power.

Aimer Test

Activate the aimer by pressing the "On / Off" button. The display will scroll "**Hoppy – Vision 100 Headlamp Alignment System**". Insure that the display does not indicate a battery low condition. If "**Battery Low**" is indicated, you should plug in the battery charger and proceed or charge overnight, then proceed.

Press the "**Align to Vehicle**" button. This will activate the laser located on the side of the aim head next to the mast. The laser should turn on as it will be used for vehicle alignment.

Press the "**Align to Lamp**" button. The display should display "**Align: Lamp Too Dim.**"

Press the "**Aim Lamp**" button. The display should indicate "**Low Audit: Lamp Too Dim.**" Pressing the button again the display should indicate "**Low Adjust: Lamp Too Dim.**" Pressing the button again should indicate "**High Audit: Lamp Too Dim.**" Pressing the button again should indicate "**High Adjust: Lamp Too Dim.**" Pressing the button again should indicate "**Fog Adjust: Lamp Too Dim.**" You should be able to toggle through these functions continually.



VISION 100 COMPONENT DESCRIPTION

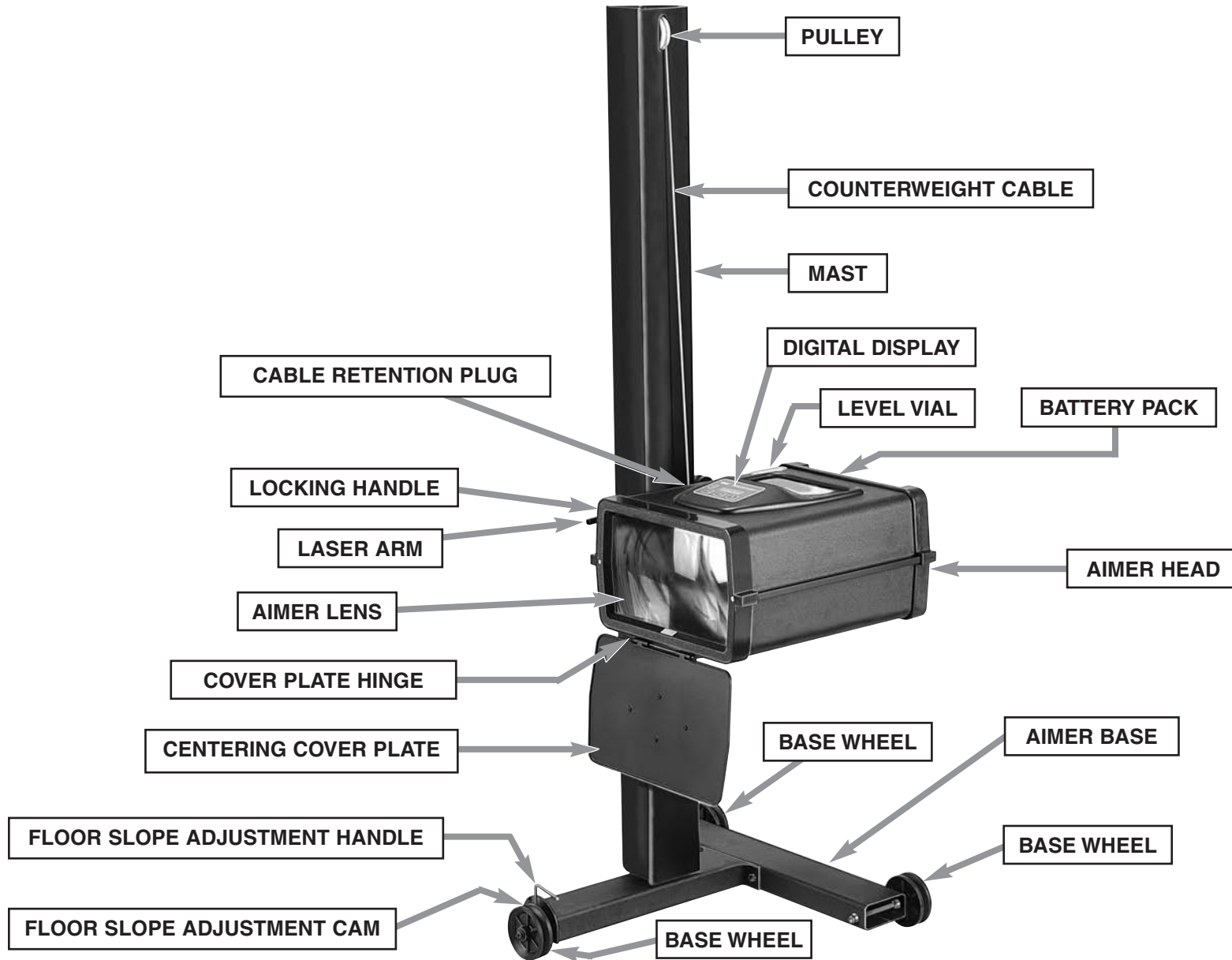



SET FLOOR SLOPE

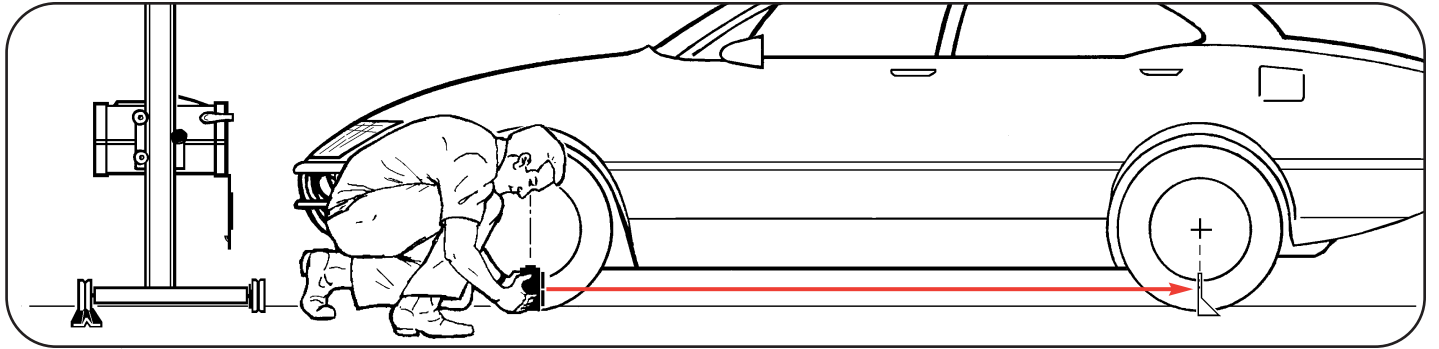
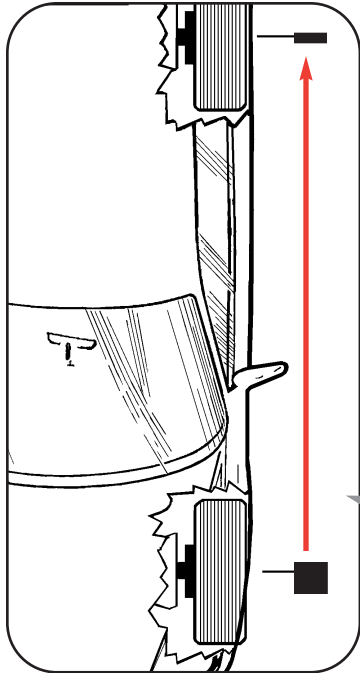

STEP 1:

Since few shop areas have the same floor slope, the slope of each aiming bay must be individually measured and entered. A Hoppy® Model G2 Split Image Transit with target is provided to measure floor slope. Place the transit at the front wheel (either side) of the vehicle and place the target at the rear wheel on the same side.

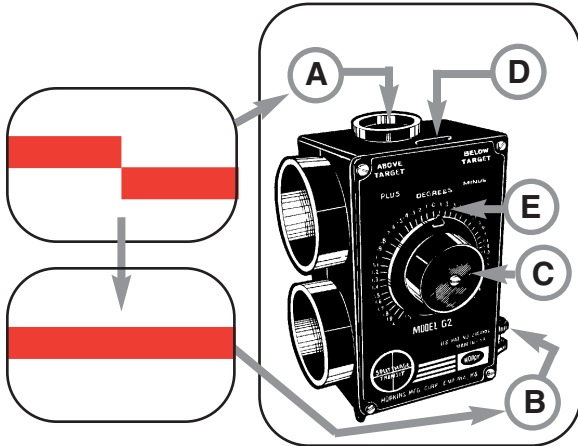

STEP 2:

- Looking through the viewing window (A) on top of the transit, turn the small thumb screw knob (B) until the black lines of the target (in the viewing window) are in a straight line.
- Now turn the level indicator dial (C), on side of transit, until the bubble (D) is centered.
- The floor slope reading is indicated by level / indicator dial (E). A plus (+) or (-) reading indicates the slope of the floor / vehicle.

STEP 3:

Now loosen the floor slope adjustment handle and move the adjustment handle until the level vial on top of the aimer head is centered. Tighten the floor slope adjustment handle. This levels the aimer head and establishes an arbitrary "0" on the floor slope scale. Next, take the (+) or (-) reading established in Step 2; again loosen the handle and **add or subtract** the number of increments **from the arbitrary "0" location at the line on the cam**. Retighten the adjustment handle. Floor slope is now set for that bay. A decal on the back of the aimer is provided to record multiple bay floor slope readings.

FLOOR SLOPE ADJUSTMENT HANDLE

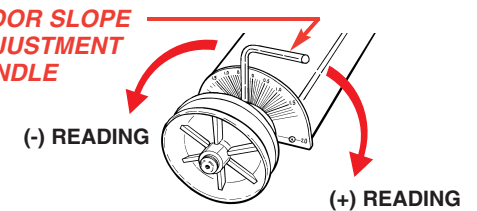



STEP 1: Vehicle Setup

The aiming floor should be relatively clean and dry with no unusually uneven areas that could affect the positioning of the vehicle or aimer.

Drive the vehicle to be checked into the aiming area, set the parking brake.

Vehicle preparation should include the following:

- Remove ice or mud from under the fenders.
- See that no tire is noticeably deflated.
- Check for sagging or broken springs.
- See that there are no unusual loads in the vehicle.
- Check function of "level ride control", if applicable.
- Clean lamp lenses.
- Check for lamp burn-out, proper beam switching, and moisture condensation. Replace lamp if moisture is present.
- Stabilize suspension by rocking vehicle.
- The vehicle headlamps must be turned on to aim the lamps.
- Locate the horizontal and vertical adjustment screws. For many vehicles, the hood must be raised to gain access to the adjustment screws.

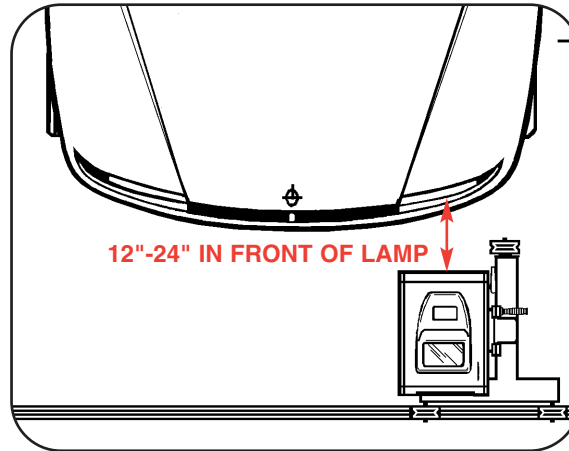

STEP 2: Aimer Alignment

Prior to alignment, insure that the Vision 100 aimer is adequately charged and working properly. Also be sure the correct floor slope is set for that bay. Lay the aimer track approximately three feet in front of and parallel to the front of the vehicle.

Alignment To Vehicle

Place the two rear wheels on the track and move the aimer so that the aimer head is in front of a lamp. The aimer and track should be positioned so that the front of the aimer head is approximately 12- 24 inches from the lamp. The aimer and track should be positioned so that the aimer can move from side to side, lamp to lamp.

STEP 3: Aimer Alignment

- Turn the aimer on and press the "Align to Vehicle" button.
- Move the aimer on the track until the laser is located at a point on the center of the vehicle grill.
- Rotate the laser up towards the rearview mirror and rotate the aimer head to position the laser dot on the center of the windshield mount.
Note: It is very important that care is taken in this setup and that the mirror mount is precisely in the center of the windshield.
If there is doubt that the mirror mount location may not be exactly in the center, then determine center by measuring and marking the windshield at this point with masking tape, marker, etc.; in addition a ridge or valley through the center of the hood may also be used.
- Rotate laser down towards center of grill. Move aimer on track right or left to position laser dot on grill center.
- Repeat these movements until an imaginary straight line is drawn from the center point of the rearview mirror mount or the marked center point of the grill.
- You are now aligned to the vehicle.



VEHICLE SETUP AND AIMER ALIGNMENT

**FIRST...
MOVE THE
AIMER
LEFT OR
RIGHT
ON THE
TRACK
TO LOCATE
THE
CENTER
OF THE GRILL...**

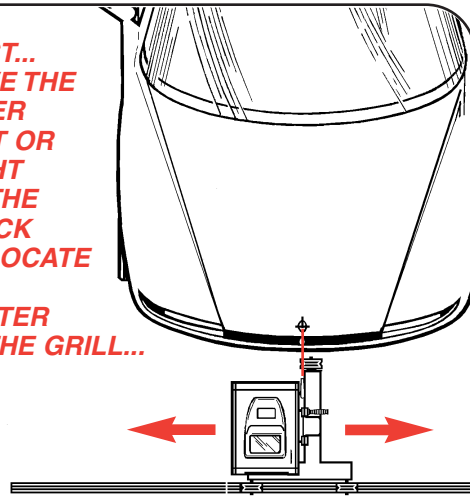

**THEN...
ROTATE
LASER
UP AND
IF
NEEDED
ROTATE
THE
HEAD
TO
LOCATE
THE
CENTER
OF THE
REARVIEW
MIRROR...**

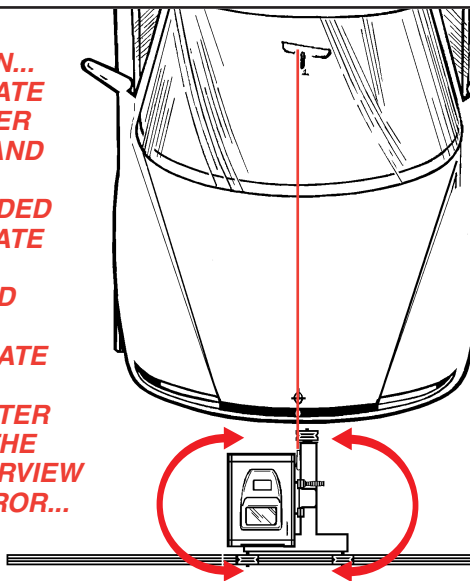

NOTE: Laser targets are provided to hang on the rearview mirror mount to assist in laser dot visibility as close as possible to the window mount.

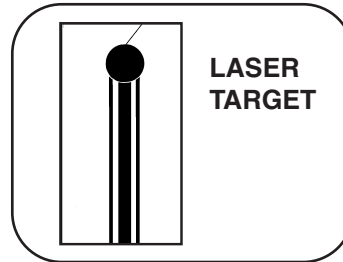

LASER
TARGET

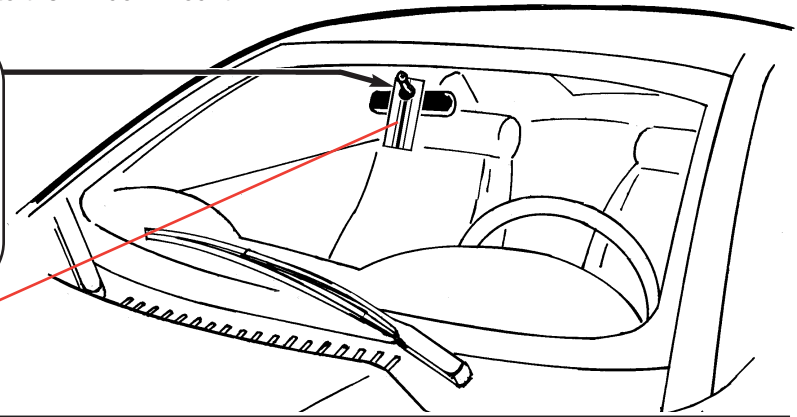

**REPEAT THESE MOVEMENTS
UNTIL AN IMAGINARY
STRAIGHT LINE IS DRAWN
FROM THE CENTER OF THE
REARVIEW MIRROR TO THE
CENTER POINT OF THE
GRILL.**

**THE VISION 100 AIMER IS
NOW ALIGNED TO THE
VEHICLE.**

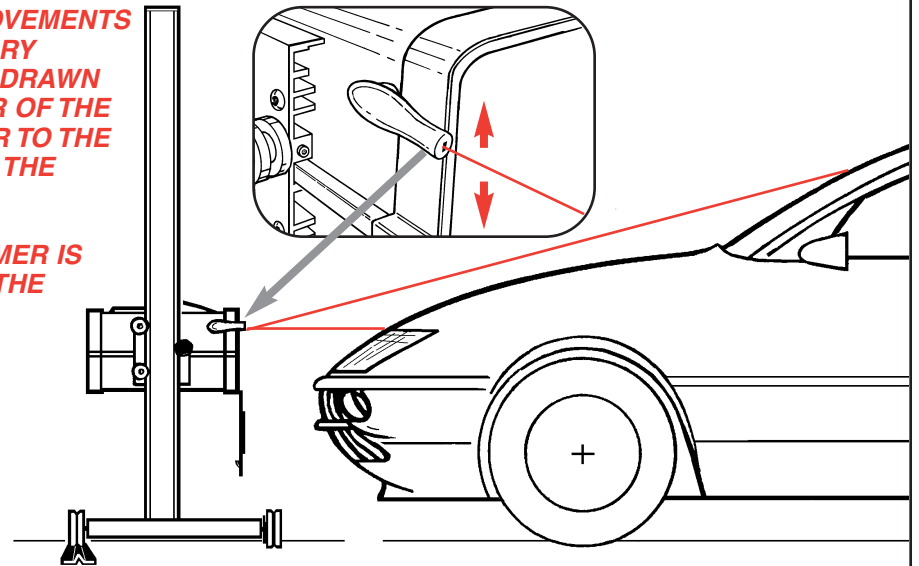



STEP 1: Position Aimer

Carefully move the aimer (left to right on the track only) in front of one of the lamps without changing the alignment of the aimer head completed in Step two.

STEP 2:

With the aimer ON and with the headlamps ON and at low beam, press the "Align to Lamp" button. This function is used to locate the **optical center** of the lamp.

STEP 3: Find Optical Center

- To find the optical center of the lamp, with cover plate closed, place the aimer in front of headlamp until arrows appear
- NOTE:** "Lamp too Dim" or "Double X's" can appear when aligning aimer to lamp when aimer is too far off optical center of the lamp.
- When **arrows** are displayed **they indicate the direction** that the **aimer head needs to be moved** either to the left or right on the track... or up and down on the mast.

STEP 4:

When both X's are displayed both axis are aligned correctly and you have properly located the center of the lamp. Turn locking handle clockwise to lock aimer head in place gently.

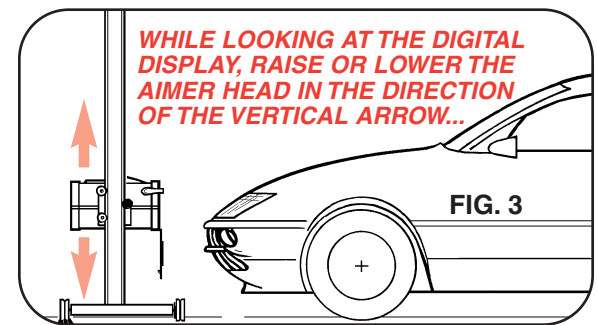
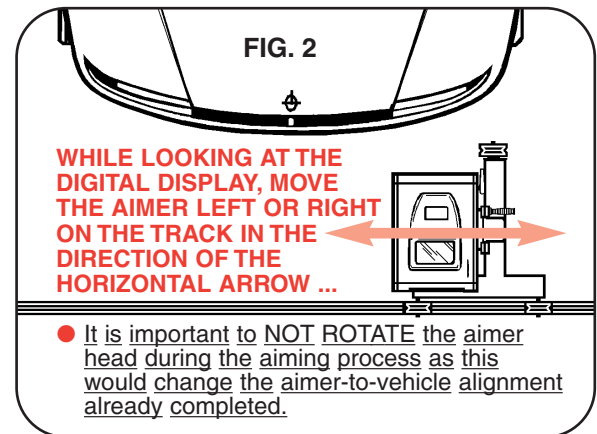
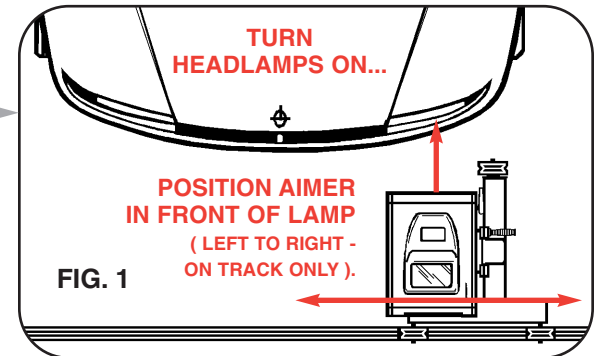



NOTE: Vehicles with headlamp mounting heights of 36" (90 cm) and up should follow these recommended J599 guidelines.

VERTICAL BEAM AIM GUIDELINES

Headlamp (centerline) Mounting Height	Nominal Vertical Aim	Aim Inspection Limits for Vertical Aim
56 to 90 cm (22 to 36")	0 Vertical	10 cm (4") Up to 10 cm (4") Down*
90 to 120 cm (36 to 48")	5 cm (2") Down*	5 cm (2") Up to 15 cm (6") Down*
120 cm to 140 cm (48 to 54")	6.4 cm (4") Down*	4 cm (1.5") Up to 16.5 cm (6.5")

To set beam 2" to 4" down on these lamps, change floor slope adjustment in the negative direction .4 degrees (2") or .8 degrees (4") from current settings.



STEP 1: With the aimer ON and with the front cover down and with the headlamps ON and at low beam, press the "AIM LAMP" button.



STEP 2: Audit Lamp

- Observe the digital display. The aimer defaults to a **low beam audit function** and the display will indicate **Low-Audit**. If the headlamp is within approved state standards (plus or minus four inches vertical and plus or minus four inches horizontal), an **X will be displayed in both the vertical and horizontal positions** on the digital display. Also indicated will be the lamp candela reading. The audit is complete and the lamp does not need to be aimed when an X appears in both positions.
- If one or both aren't within state specifications, an arrow or arrows will be displayed indicating that the lamp should be aimed.

STEP 3: Aim Lamp

- To aim the headlamp, press the "AIM LAMP" button.
- **It is important to note that arrows may now appear even though they have passed the aim audit. The audit is within the 4 inch window described above. To aim the lamp now would give accuracy beyond what is required by state specifications.**
- An Arrow indicates that the lamp needs adjustment (lamp adjustment varies - see vehicle owners manual) in the direction of the arrow shown on the aimer display until an X replaces the arrow for both the horizontal and vertical aim on the display. **THIS HEADLAMP IS NOW AIMED.**

STEP 4: Aim Other Lamps

- Carefully move the aimer without rotating the head and causing a misalignment to the opposite headlamp and repeat the above procedure.

If the vehicle has a four headlamp system or fog lamps, step the Aim Lamp button to the desired lamp style. Then repeat the above procedure for each of the remaining lamps. You will need to **turn on high beam** lamps when auditing or aiming high beams.



THE EXAMPLE (LEFT) SHOWS THAT THE LAMP IS WITHIN STATE SPECIFICATIONS AND DOES NOT REQUIRE HEADLAMP AIM.



THE EXAMPLE (LEFT) SHOWS THAT THE LAMP DOES REQUIRE VERTICAL ADJUSTMENT TO BE WITHIN STATE SPECIFICATIONS.

***NOTE:** To lower headlamp aim 2" or 5 cm @ 25 ft., rotate the floor slope adjustment lever .4 degrees in the negative direction.

***NOTE:** To lower headlamp aim 4" or 6.4 cm @ 25 ft., rotate the floor slope adjustment lever .8 degrees in the negative direction.

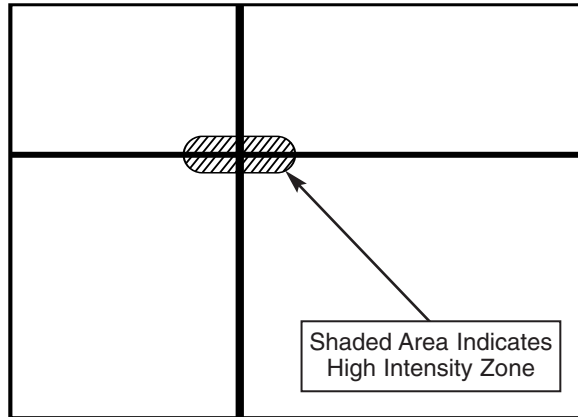

Properly Aimed Upper Beam

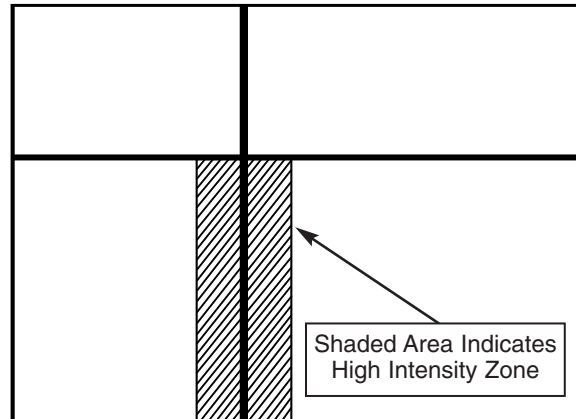

Aim Inspection Limits for Symmetrical Beam Fog Lamps

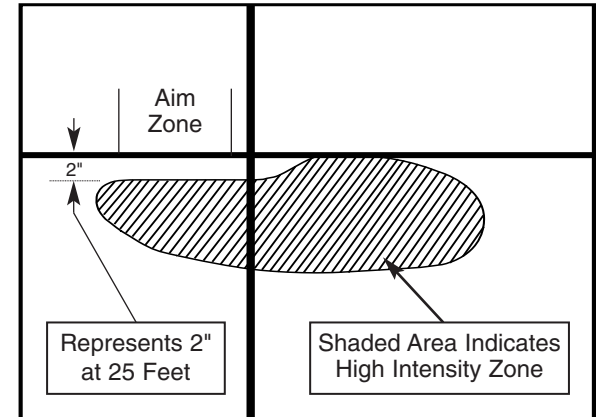

VOL

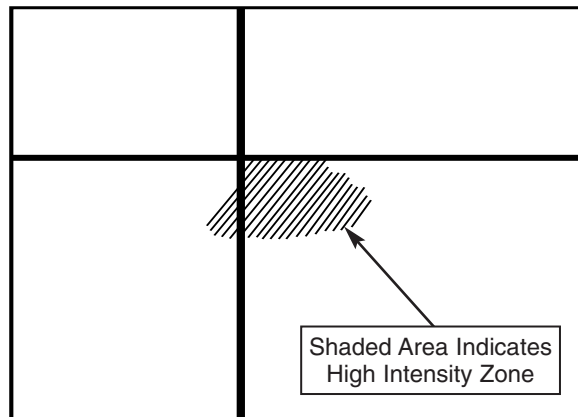

Properly Aimed Lower Beam

Note:

Although all US headlamp beam patterns meet the same Federal specification, one may encounter a lamp that is difficult to aim electronically and or visually. If it is suspected the aimer is not aiming the lamp correctly, look for the following conclusions. The aimer may be defective and should be compared to other known vehicles. If it does not aim these vehicles properly return to factory for repair. If it aims these vehicles properly, recheck vehicle alignment and lamp centering. If the aimer continues to misaim the lamp it may be a beam pattern that is difficult to interpret. The lamp then must be aimed visually on the internal aim screen as accurately as possible.

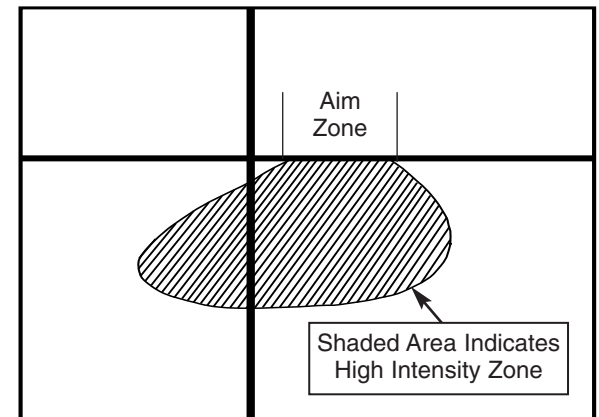

VOR



Equipment Calibration Checks

There are two critical checks for proper calibration:

- The position of the laser dot with respect to the centerline of the Aimer.
- The vertical straightness of the laser to the vertical axis of the Aim Head.

Recommended Tools:

- Four foot carpenter's level
- Measuring Tape or Ruler
- 5/64" Allen wrench

Laser Parallel to Centerline of Aim Head

1. Locate an area that is reasonably level next to a wall or any vertical surface with an opening at least 18 inches wide and 48 inches high. Place V100 Aimer next to this vertical surface with floor slope adjust wheel pointing towards the wall and front of the Aim Head approximately 30 inches from the wall.
- Level Aim Head vertically (front to back) and horizontally (side to side) as follows: Vertical leveling can be accomplished by using the Level Vial on the top of the Aim Head and adjusting the Floor Slope Adjust Lever (Fig. 2). Horizontal leveling is accomplished by placing a carpenter level across the front top bezel and adjusting the mast (Fig. 3).
2. Place an accurate straight edge (4 ft. long) along the length of the left side of the Aim Head to the wall in front of the unit using the outermost side of the front and rear bezel. Make a mark on the wall on the inside of the straight edge (Fig. 4 / 1).
3. Using the level, draw a vertical line 24 inches above and below this mark (Fig. 4 / 2).
4. Measure accurately from this mark at right angles 16 1/4 inches and make a mark on the wall (Fig. 4 / 3).
5. Using the level, draw a vertical line 24 inches above and below this mark (Fig. 4 / 4). This line locates where the tracking point of the laser should be. Press the "On/Off" button to turn unit on. Press "Align to Vehicle" button to activate laser.
6. Rotate laser pointer straightforward. Laser dot should intersect vertical on wall (Fig. 4 / 5 & 6).
7. Rotate laser pointer up vertically approximately 10-12 inches. Laser dot should intersect vertical line on wall at this point (Fig. 4 / 6).

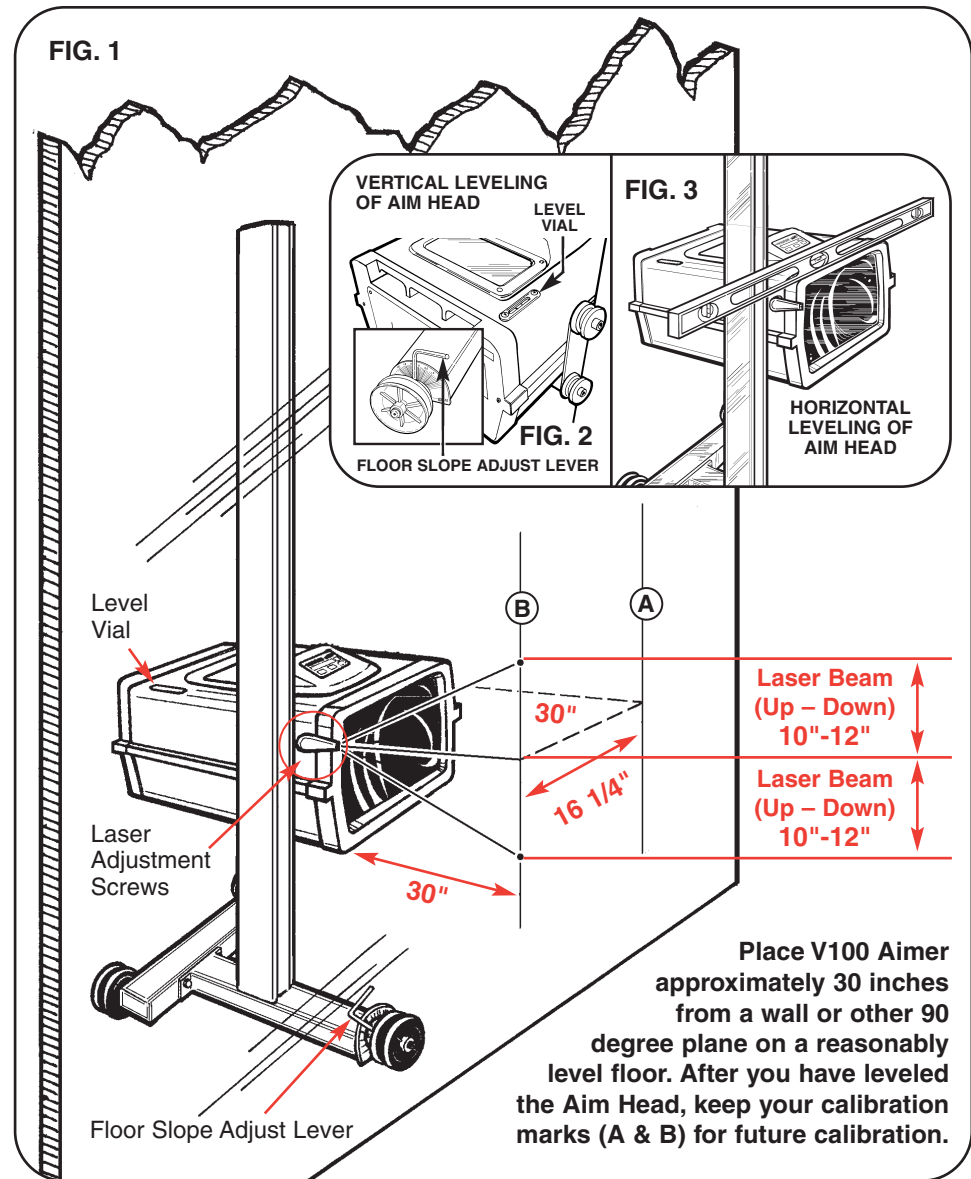



8. Rotate laser pointer down vertically 10-12 inches. Laser dot should intersect line at this point (Fig. 4 / 6).
- If the laser dot does not intersect with these three points, adjustment is necessary.
 - These vertical lines can be used in the future for calibration check or alignment (Fig. 4 / A & B).

Adjustment

There are three Allen screws and four holes located at the laser mount. Two screw heads are visible at the rear and one is located under the front lens bezel (Fig. 4 / 6). Normally the back screws will accomplish the adjustment but in extreme cases, it may be necessary to remove the Phillips head screw on the front of the lens bezel and pull the bezel back far enough to expose the front laser adjustment screw. **Be careful to not back the screws out completely allowing the nuts inside to fall.**

Adjustment procedures are dictated by the location of the screw at the front under the lens bezel.

Adjustment Procedure

- Position the laser pointer straightforward. If the front screw is located at the top, adjust the rear top screw to bring laser dot horizontally to the vertical line.
- If the front screw is located at the bottom, adjust the rear bottom screw to bring the laser dot to the vertical line. This is a rough adjustment.
- Rotate the laser pointer up as described above and adjust the opposite rear screw to align the laser dot with the vertical line. This is a fine adjustment.
- Rotate the laser pointer downwards and adjust the screw to align the laser dot with the vertical line.
- Repeat these adjustments until the laser dot tracks accurately from 10-12 inches above to 10-12 inches below the straight ahead position.
- This completes the adjustment.

Mast Straightness

While V100 is in front of the vehicle, Place level across the top front bezel of Aim Head to check horizontal level. If necessary, loosen bolts on the base and adjust mast.

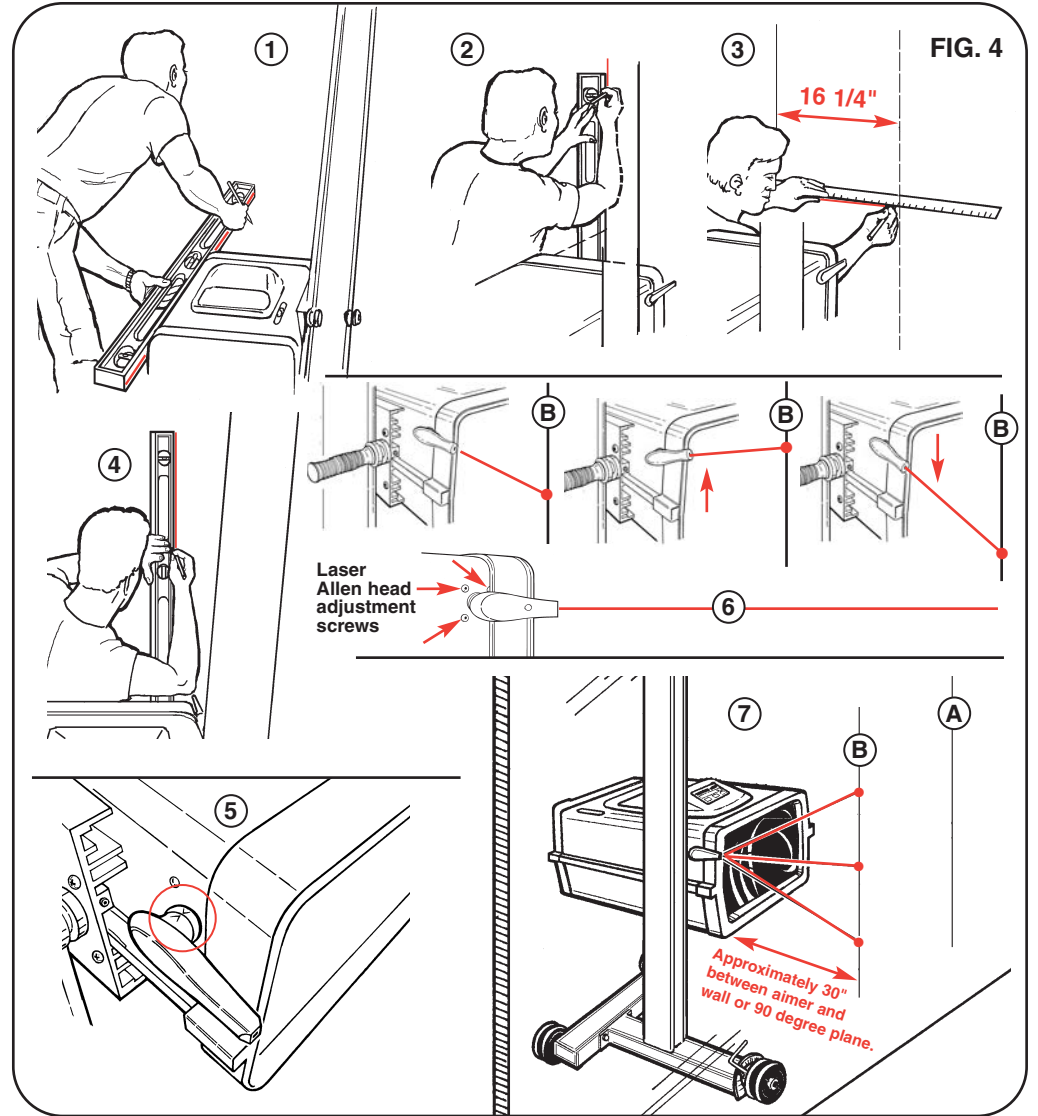

This supersedes Vision 100 calibration page 11 of manual.



Vision 100 Performance Specifications

Equipment Performance Specifications

<i>Field Specifications</i>	<i>Value</i>
Field of View	$\pm 49^\circ$ V x $\pm 65^\circ$ H @ 25'
Candela	1,000 – 100,000 candela
Temperature	32 – 110 degrees F
Storage Temperature	0 – 120 degrees F
Humidity	Non-condensing
Update Speed	1 update / sec (maximum)
Accuracy	4" @ 25'
Repeatability	1" @ 25'
Power	Ni-Cad battery pack & 9 VDC Wall Charger
Voltage Input	7.2 – 9.0 VDC
Battery Life (continuous)	± 4.25 hours
Headlamp Styles	US Low Beam US High Beam Fog Lamp
Aim Algorithms	Fractional Zone Aim (FZA) Hot Zone Aim (HZA)
Floor Slope Compensation	Adjustable $\pm 2^\circ$
Packaging	3 Packages – UPS Shippable



Symptoms	Possible Cause(s)	Diagnosis
Mast turns too easily or not at all	1. Incorrect tension adjustment	1. Remove the mast and tighten or loosen the bolt on the top of the outer swivel (see Fig. 2 in the Assembly Procedure).
Mast eventually works loose after adjusting the tension	1. Tension bolt	1. The tension bolt of the mast has a nylon insert to keep the bolt from becoming loose during operation. If the tension needs to be adjusted continually, 1-877-343-7703 .
Floor slope scale will not lock in position	1. Handle loose 2. Shoulder bolt loose	1. Tighten the handle on the floor slope cam to lock the cam. 2. Remove the front wheel on the floor slope adjusting cam. The round cam has a 3/8" shoulder bolt that should be tight without affecting the movement of the cam. Tighten the shoulder bolt and attach the wheel. If problem is not corrected, call 1-877-343-7703 .
V100 aim head wobbles on mast	1. Tension wheel	1. On the side of the aimer is 3 wheels. The front single wheel can be adjusted by tightening the set screw on the front edge of the side extrusion where the front wheel is mounted (see Assembly Fig. 6 in the Assembly Procedure). Note: When tightening set screw, you may experience some resistance, continue to tighten until tension wheel removes excessive rocking or wobbling.
V100 aim head will not fit over mast or has stiff movement	1. Tension wheel	1. To loosen the tension wheel, loosen set screw on the side mount extrusion (see Fig. 6 in the Assembly Instructions). Loosen lock nut on tension bolt and force wheel assembly toward the front of the aimer to allow for play. Tighten tension bolt nut until it's snug (see Fig. 6 in the Assembly Instructions). Place head on mast and tighten set screw until tension wheel is adjusted properly. Note: When tightening set screw, you may experience some resistance, continue to tighten until tension wheel removes excessive rocking or wobbling.

For technical assistance call: 1-877-343-7703



Symptoms	Possible Cause(s)	Diagnosis
High Candela Readings	<ol style="list-style-type: none">1. Filter glass2. Lamp	<ol style="list-style-type: none">1. With the front cover open, look inside through the top view lens toward the aim screen with cross hairs. A blue filter glass should be attached to the center of the aim screen. If the glass has become dislodged, call 1-877-343-7703.2. Some lamps can have candela readings as high as 70,000. If the readings only occur on certain lamps, then the unit is set correctly. If the readings are always 100,000 on all lamps, call 1-877-343-7703.
“Lamp Too Dim” signal when Aligning to Lamp. (finding center of lamp)	<ol style="list-style-type: none">1. Operating mode2. Front cover open3. Dim lamp	<ol style="list-style-type: none">1. Verify that the unit is in “Align To Lamp” mode and not “Aim Lamp” mode.2. The front cover must be closed when aligning the V100 to the lamp.3. If the headlight is very dim or dirty, it can affect the candela output of the lamp. It may be necessary to start the vehicle on a dimmer lamp, if the lamp does not need to be replaced or cleaned. Call 1-877-343-7703 if the problem is not resolved.
“Lamp Too Dim” signal when Aiming Lamp. (adjusting or auditing a lamp)	<ol style="list-style-type: none">1. Front cover closed2. Operating mode3. Lamp way out of adjustment4. Dim lamp	<ol style="list-style-type: none">1. The front cover must be open when the unit is in the “Aim Lamp” mode.2. Verify that the unit is in “Aim Lamp” mode and not “Align To Lamp” mode.3. With the headlights on and shining into the V100 aimer, look through the top view lens and verify that the headlights hot spot is shining on the blue filter glass. The lamp may need to be adjusted visually until the hot spot appears to be shining in the center of the cross hairs or blue filter glass.4. If the headlight is very dirty or dim, it can affect the candela output of the lamp. Also, low battery voltage will cause a dim lamp. It may be necessary to start the vehicle to increase lamp brightness.



Symptoms	Possible Cause(s)	Diagnosis
Lamp Too Dim (Cont'd.)	5. V100 too far from lights	5. Make sure the unit is within 25 inches of the headlights, if a “ Dim Lamp ” signal appears. If the problem cannot be resolved, call 1-877-343-7703 .
Unit will not charge (Low battery)	1. Charger defective 2. DC jack defective 3. Cable loose or defective 4. Battery defective	1. Plug charger into 120 volt outlet and using a DC voltmeter, check the output voltage of the charger. Voltage readings can range between 12 and 18 DC volts. If the readings are acceptable, proceed to Number 2. If the readings are not in range, call the 1-877-343-7703 . 2. Using the 4 screws on the back of the V100, remove the back cover plate. Disconnect the battery cable connector so the battery is not powering the unit. Now plug the charger into the V100 DC jack and try to turn on the unit. If the V100 will not power up with only the charger, call 1-877-343-7703 . If the unit works with the charger proceed, to Number 3. 3. While the unit is still plugged into the charger and with the battery disconnected, take a voltage reading on the battery connector cable coming from the main PCB board. The voltage reading should be within 2 or 3 volts of the charger reading taken in Step 1. If a reading cannot be obtained, call 1-877-343-7703 . If a voltage reading occurs, proceed to Number 4. 4. Remove the battery pack from the unit and check for loose wires. Using a voltmeter, check the output voltage of the battery. It may be necessary to move the wires on the battery's connector while reading the voltage to check for shorts. Note: The unit will not power up on the battery alone, if the voltage drops below five volts. If the battery appears to be defective, call 1-877-343-7703 . If the battery checks OK, let the unit charge overnight. If unit still fails to charge, call 1-877-343-7703 .



Note: It is critical to have the aim head parallel to the headlamps on the vehicle. The track can run off parallel as long as the aim head remains parallel to the vehicle.

EXAMPLE 1:

Aim head is misaligned to the vehicle with the track parallel to the vehicle. Aimer will miss-aim lamps.

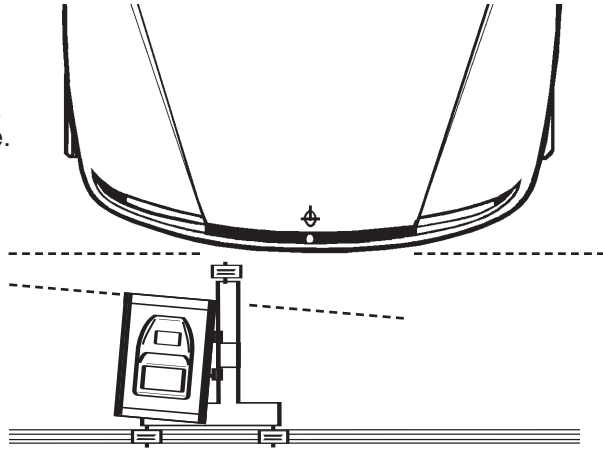

EXAMPLE 2:

Aim head is aligned parallel to the vehicle with the track parallel to the vehicle. Aimer will aim lamps correctly.

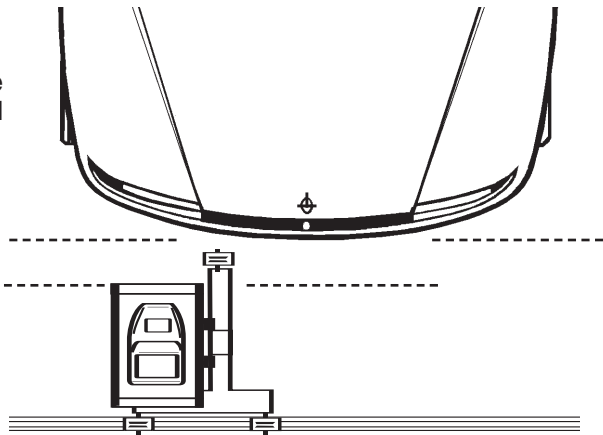

EXAMPLE 3:

Although the V100 aimer travels along a track that is not parallel to the vehicle, the aim head can be aligned parallel to the vehicle.

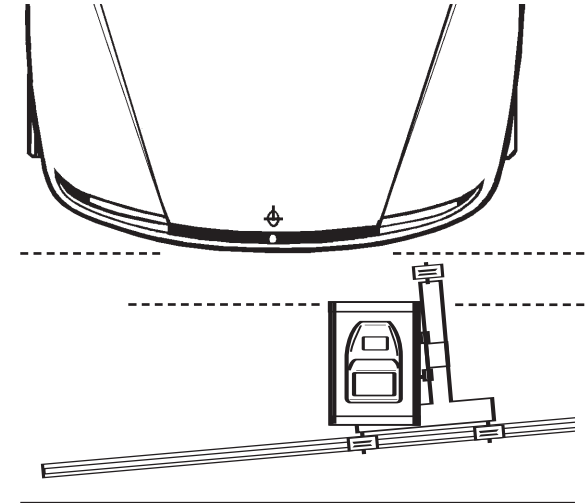

The second image shows the V100 at the second headlight and remains parallel to the vehicle. Aimer will aim lamps correctly.

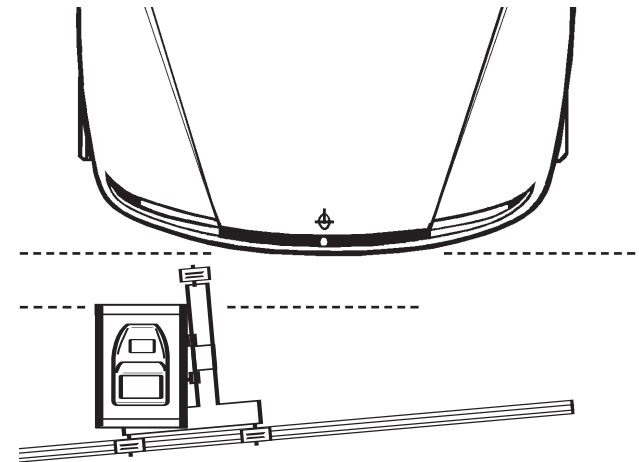



STEP 1:

Verify laser calibration. See Instruction Manual Calibration procedure.

STEP 2:

If laser is calibrated correctly, then it may be necessary to recalibrate the V100 head setting for left to right level.

STEP 3:

To correctly adjust the V100 aim head to correct misalignments, identify shop floor conditions by viewing the following examples:

EXAMPLE 1: Ideal Shop Floor

When aligning the aimer to the car the aim head should be level left to right.

EXAMPLE 2: Shop Floor Settling Uneven

As long as the V100 head is level left to right as is the car during **Aimer to Vehicle Alignment**, the aimer can roll off level without causing misalignment of the lamps.

EXAMPLE 3: Shop Floor Settling Level

This example shows that if the aimer and vehicle are both on the same plane and the surface is not level, then alignment will not be affected.

EXAMPLE 4: Vehicle Surface Level, Aimer Surface Uneven

Place the aimer in front of the vehicle where the alignment to vehicle takes place. Using the base adjusting sections, level the V100 aim head left to right so the head now reads level while setting on the uneven surface. See Page 4, Fig. 11 of the Assembly Instructions for level reading.

EXAMPLE 5: Vehicles Surface Uneven, Aimer Surface Level

Place the aimer in the area in front of the vehicle where alignment to vehicle takes place. Using a level, take a bubble reading of the uneven surface where the vehicle sets. Using the base adjustments sections, set the level of the aim head to be off level the same amount as the vehicle. This will put the vehicle and the aimer on the same plane. See Page 4, Fig. 11 of the Assembly Instructions for level reading.

NOTE:

For the vehicle and the aimer to be aligned parallel, it is critical that the aimer and the car are on the same plane when aligning the V100 to the vehicle.

EXAMPLE 1:

Vehicle sets on level surface. Aimer moves left to right on level surface.

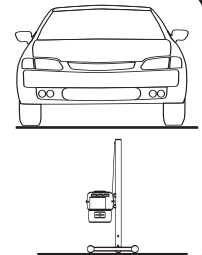

EXAMPLE 2:

Vehicle sets on level surface. Aimer sets on level surface where aimer is being aligned to vehicle.

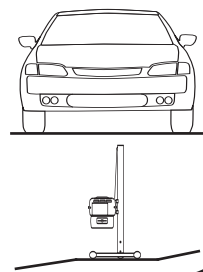

EXAMPLE 3:

Vehicle sets on not level surface. Aimer sets on not level surface, same as vehicle.

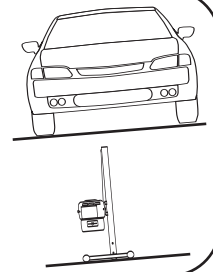

EXAMPLE 4:

Vehicle sets on level surface. Aimer sets on not level surface. **Note:** properly adjusted base.

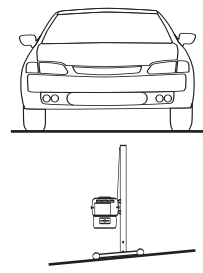

EXAMPLE 5:

Vehicle sets on not level surface. Aimer sets on level surface. **Note:** properly adjusted base.

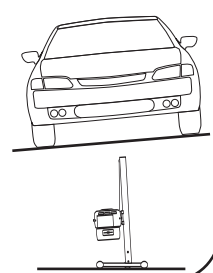



Questions

- 1. Do I have to use the track with my Vision 100?**
- 2. Do I need to mount the track to the floor?**
- 3. Can I purchase extra track for extra bays?**
- 4. Where can I store the track when not in use?**
- 5. Do I have to square the track to the vehicle every time I set the unit up?**
- 6. Will I need to compensate for the track when setting floor slope?**
- 7. What kind of warranty does the V100 have?**
- 8. Will I still be covered by the warranty if I do not send in my registration card?**

Answers

For best performance, we suggest the track be used to prevent the aimer from moving off parallel when rolling the unit to the left and right side of the vehicle. However, if the shop floor is clean and smooth then the track may not need to be used.

No, the track does not need to be mounted to the floor.

Yes, extra track is available for purchase in 2 sections of 4 feet each.

The track can be stored inside the mast.

The track does not have to be square with the vehicle, only the aimer does. See the Troubleshooting Guide, "Misaligning Lamps."

No, the floor slope scale is designed to compensate for the track thickness.

The Vision 100 is covered by a 90-day replacement warranty and a full year parts and labor.

Yes, but non-registered units will require longer processing time and cause unnecessary confusion. You will also need to include purchase documentation. If a registration card was not received with the V100, call **1-877-343-7703** and one will be sent to you. If registration cards are lost in the mail, we will accept a proof of purchase with a legible date of purchase for warranty coverage.



WARRANTY

WARRANTY AND LIMITATION OF REMEDY

Seller warrants that the items sold will be free from defects in material and workmanship for a **period of one year** from the date of purchase; provided, however, that Seller's maximum liability and Buyer's exclusive remedy, for any goods which are or become defective, shall be, at Seller's option, the repair of the defective goods or the replacement thereof with conforming goods, f.o.b. Seller's plant, or the reimbursement to the Buyer of the contract price for the defective goods. Repair or replacement of defective goods or reimbursement for the contract price therefore, shall be made only upon return of the defective goods to Seller at Seller's cost, but only after inspection of the goods by Seller and written instructions by Seller to Buyer regarding the shipment of the goods to Seller.

Other than as set forth above, **SELLER MAKES NO WARRANTY OF ANY KIND, WHATEVER, EXPRESS OR IMPLIED; AND ANY IMPLIED WARRANTY OF MERCHANTABILITY OR FITNESS FOR A PARTICULAR PURPOSE IS HEREBY DISCLAIMED BY THE SELLER.**

Seller shall not be liable for any consequential damages, loss or expense arising from the use or the inability to use the goods for any purpose whatsoever.

There are no warranties by Seller covering components, parts or accessories specified by the Buyer and manufactured by someone other than Seller. Such warranties as may be furnished to Seller by the manufacturer of such items will be extended to the Buyer by the Seller.

The **Vision 100 Headlamp Aiming Unit is an optical aiming system designed to aim headlamps that comply with The Society Of Automotive Engineers recommended practices described in J599 and J600.** All lamp and lamp patterns do not conform to these recommended practices. While the Vision 100 Headlamp Aiming Unit is not designed for use on lamp and lamp patterns which do not conform to the recommended practices, the unit includes alternate methods which may conform to the recommended practice as described in J600.

SELLER MAKES NO REPRESENTATION OR WARRANTY OF ANY KIND, WHATEVER, THAT THE VISION 100 HEADLAMP AIMING UNIT WILL AIM HEADLAMPS WHICH DO NOT CONFORM TO THE SOCIETY OF AUTOMOTIVE ENGINEERS RECOMMENDED PRACTICES DESCRIBED IN J599 AND J600.



Wall Industries, LLC

P.O. Box 725 • 3529 W. 6th Ave. • Emporia, KS 66801

Tel: 620-343-7700 • Toll Free: 877-343-7703 • Fax: 620-343-7705